

- HS9 Cup spring 1mm
- HS10 Cup spring 1mm

- HS1 Head Screws M2,5 x 6
- HS2 Head Screws M2,5 x 6
- HS3 Head Screws M2,5 x 6
- HS4 Head Screws M2,5 x 6
- HS5 Head Screws M2,5 x 6
- HS6 Head Screws M2,5 x 6
- HS7 Head Screws M2,5 x 6
- HS8 Head Screws M2,5 x 6
- SN1 spacer bolts M2,5 12x6mm
- SN2 spacer bolts M2,5 12x6mm
- SN3 spacer bolts M2,5 12x6mm
- SN4 spacer bolts M2,5 12x6mm

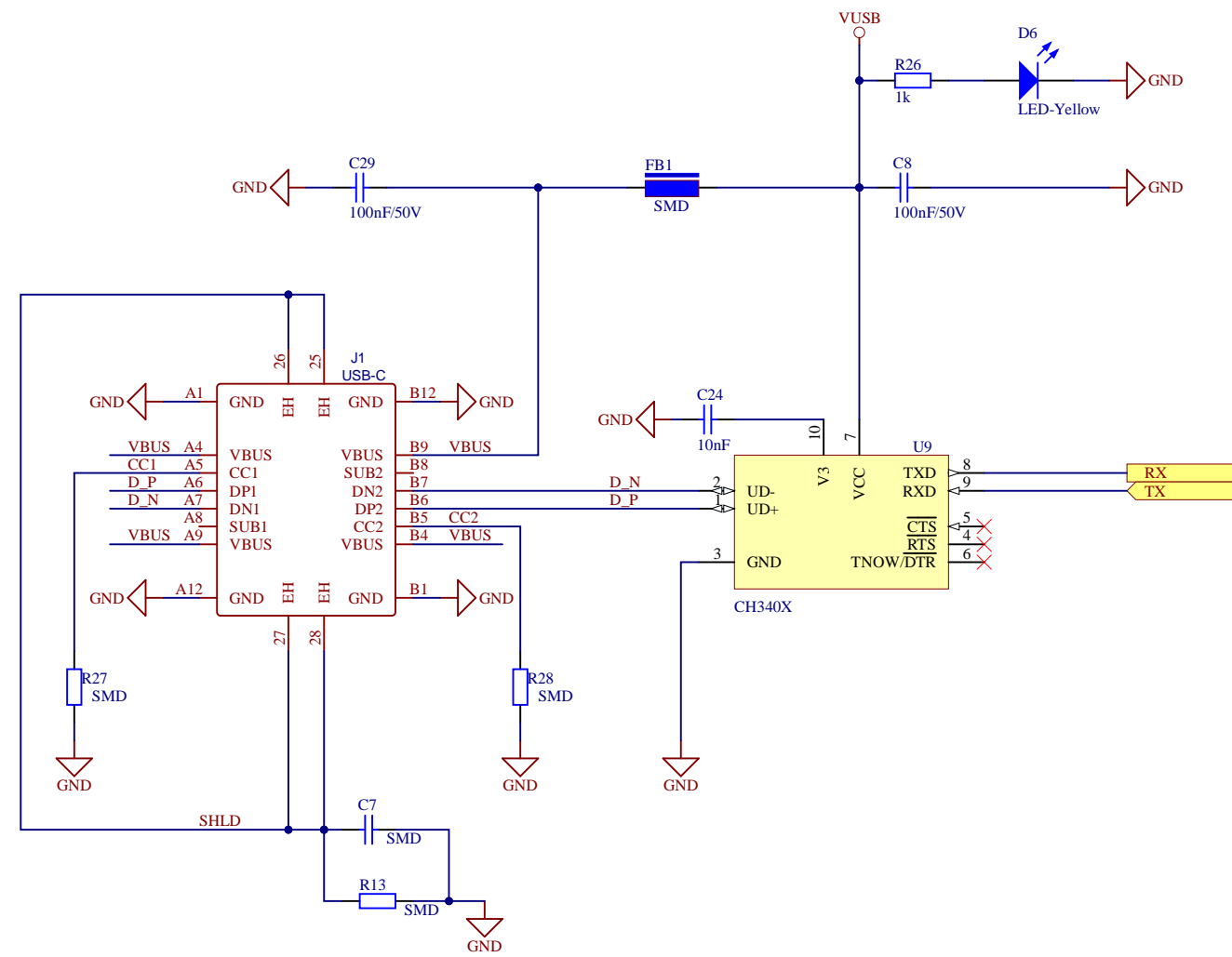

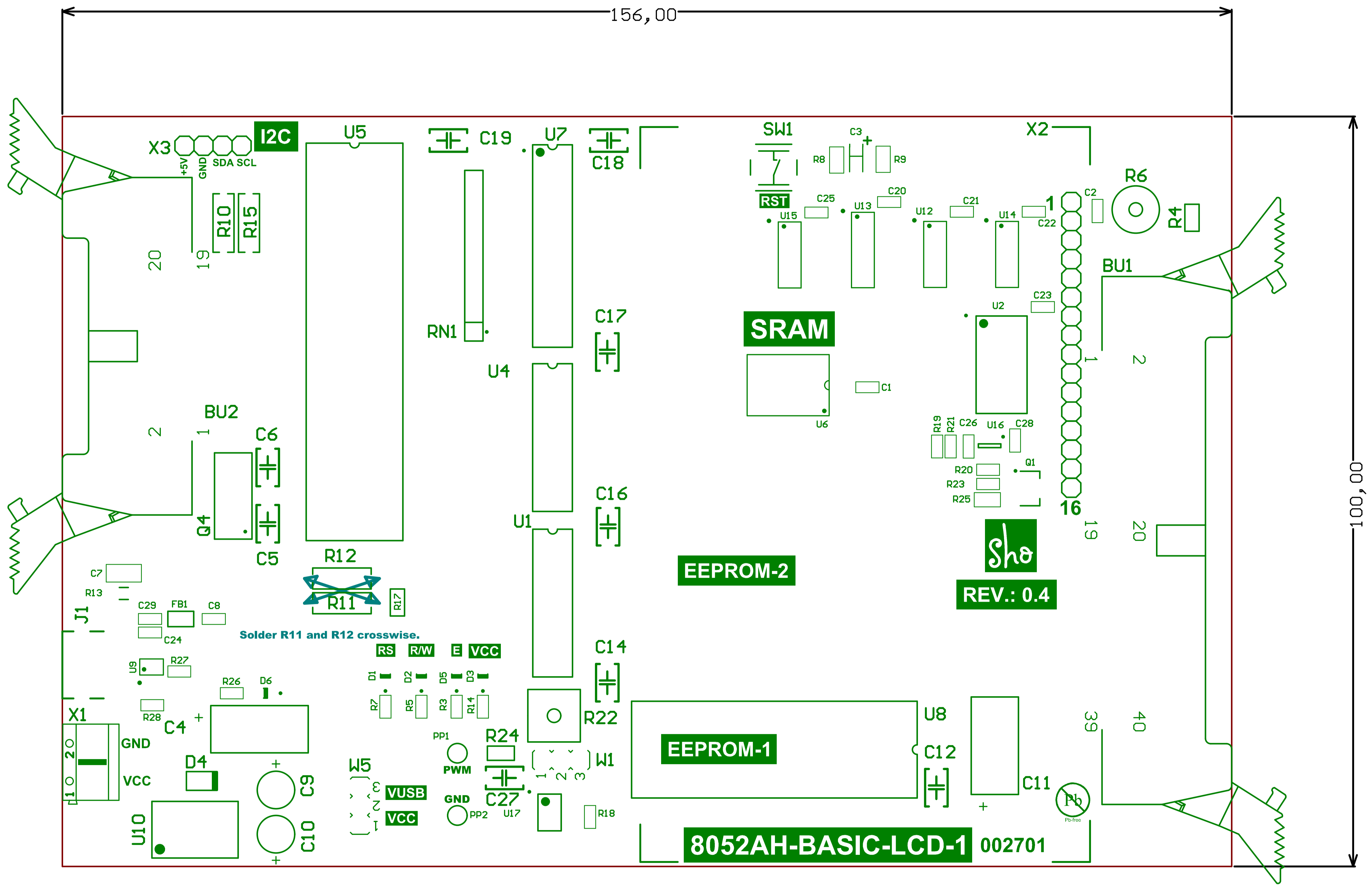



Bearbeiter: S. Hofmann
 Tel: 040 /
 Fax: 040 / 76906856
 Email: shop@shotech.de

Bill of Materials

Datum:	24. März 2026
Zeit:	14:28:14
Variante:	Variant of P8052AH-BASIC-LCD-1
Bezeichnung:	8052AH-BASIC Board EEPROM
Revision:	0.4
Description:	summary

Quantity	Designator	Footprint	Bemerkung	Value	MFT	Order-Code	Second-source	shotech
1	BU1	IDC2.54-H40A - duplicate	SEK-18 SV MA STD ANG29 RKZ 40P PL3	09 18 540 7903	Harting	09 18 540 7903	PSL-40W	
1	BU2	IDC2.54-H20A	SEK-18 SV MA STD ANG29 RKZ 20P PL3	PSL 20W	Harting	09 18 520 7913	Reichelt - PSL 20W	
1	C4	CAPPA6.3mm x 13mm	Elko axial 100µF 16V 6,3x13mm +85°C	10µF/35V	SUNTAN	TS13AE1V100MSB000R		
1	C5, C6	CAP_Radial_5MM	Ker-Ko 22pF 50V RM5,00 5% NPO/COG	22pF	TDK	FG28C0G1H220JNT06	FG28C0G1H220JNT00	2387
2	C9, C10	CAPPR2-5x11 - RM2.5	22µF/63V/20%/2000h/RM2.5/85 °C	22µF/63V	Samwha	SD1J226M05011PC359		1338
1	C11	CAPPA6.3mm x 13mm	Elko axial 100µF 16V 6,3x13mm +85°C	100µF/16V	SUNTAN	TS13AE1C101MSB000R		
1	C27	CAP_Radial_5MM	100nF/50V/±10%/X7R/RM 5.08	100nF/50V	Vishay / BC Components	K104K15X7RF53H5	C322C104K5R5TA - shotech	1347
1	CS2		Circuit socket DIP28-LC	Circuit socket DIP28-LC	ASS	A 28-LC-TT		1521
1	CS4		Circuit socket DIP40	Circuit socket DIP40	ASS	A 40-LC-TT		1582
1	CS6		Circuit socket DIP14 präzision	Circuit socket DIP14	PRECIDIP	110-87-314-41-001101		2065
1	CS8		Circuit socket DIP16 präzision	Circuit socket DIP16	ASS	AR16-HZL-TT		2066
1	CS9		Circuit socket DIP20 präzision	Circuit socket DIP20	ASS	AR 20 HZL-TT		2067
1	CS10		Ribbon cable yellow 28	Ribbon cable yellow 28	shotech			2398
1	CS11		Circuit IDC socket 40 pin.	pin.	frei	PFL 40		
1	CS12		Circuit IDC socket 20 pin.	pin.	frei	PFL 20		
1	D4	DO41	Schottky Dioden & Gleichrichter 1.0A 40V	1N5819	Taiwan Semiconductor	1N5819 R0		1568
8	HS7, HS8		Head Screws M2,5 x 6	Head Screws M2,5 x 6	TR FASTENINGS			2101
2	HS9, HS10		Cup spring for soldering pin 1mm	Cup spring 1mm	Osterrath	64-1389-11/0030		1860
1	KL1		Circuit board	Circuit board	frei			2397
2	PP1, PP2	VERO_Testpoint_Blue	Prüfpunkt					
1	Q4	HC49/4H_SMX	Quarze +/-30ppm, 20pF, 400Ohm, 11,059200MHZ FUNDAMENTAL	11,059200MHz	HKC Europe	9SM1105920E20F3Z000		1320
1	R4, R17	RES6.5-3.4X1.9	Metallsch. 0204 1/4W 1%	0R	frei	frei		
1	R6	PT6KV	10k Trimmer	10k	Piher	PT6KV-103A2020		
2	R10, R15	RES10-7.8X2.8	WIDERSTAND, 207, 1%	100R				1678
2	R11, R12	RES10-7.8X2.8 - 1k	Metallsch. 0207 1/4W 1%	1k	frei	RMGK001		1235
1	R22	CT-6EP	50k Trimmer	50k	COPAL	CT-6EP-503		
1	R24	RES6.5-3.4X1.9	WIDERSTAND, 204, axial, 1%	220k				
1	RN1	SIP240W50P254L2276H508Q9P	Widerstandnetzwerke u. -Arrays 9pins 10Kohms Bussed	RN10k	Bourns	4609X-101-103LF		
4	SN1, SN2, SN3, SN4		spacer bolts Polyamid M2,5 12mmx6mm,	12x6mm	frei			
1	SW1	SW-DTS-644	Mini-Taster print stehend 1N	DTS-644N-V	Diptronics	DTS-644N-V		2455
1	U1	N014	Quadruple 2-Input Positive-NAND Gate	SN74HCT00N	Texas Instruments	SN74HCT00N		
1	U4	N016	3-Line to 8-Line Decoder / Demultiplexer	SN74HCT138N	TI	SN74HCT138N		
1	U5	SOT129-1	8052 mit BASIC ROM 8KB, DIP40, 5V	8052AH-BASIC	Intel	8052AH-BASIC	+	2403
1	U7	N0020A	Octal D-Type Latch, 3-State, 4,5 ... 5,5 V, DIL-20	SN74HCT573CN	TI	SN74HCT573CN		
1	U8	PDIP28	EEPROM 64K 8k x 8 150 ns 4.5V-5.5V	AT28C64-15PU	Microchip Technology / Atmel	AT28C64-15PU		
1	U10	R-78K	DC/DC Conv SIP3 6,5-36V 5V 1A	R-78K5.0-1.0	Recom	R-78K5.0-1.0		
2	W1, W5	JP2	Jumper 3pin	Jumper 3pin	frei	frei		1564
1	X1	AK500/2	AR-Klemmen 250V 2pol grau	ARK500/2	PTR-Messtechnik	AK500/2DS-5,0-V/GRAU		1576
1	X2	LCD 16 x 4 Backl	LCD Display 20 x 4 mit Backl. u. Buchse	LCD-16x4			LCD-16x4	
1	X3	1X4						